

Slicing

Formax[®]

SX330 Slicing System

High Throughput, Flexibility, and Hygiene in a Compact Machine Powers Your Business





Versatility and High Performance in a Small Footprint

Versatile Operation

- Manually adjustable shear bar and product tray guide facilitate quick product changeovers
- Simple box-style grippers accommodate a large variety of products
- Machine can be easily moved within the plant depending on production requirements

Range of Conveying Systems

- Slicer is available with a simple 1220 mm (48"), 1830 mm (72") or 2440 mm (96") bulk conveyor for transport to downstream equipment
- Conveyors available with optional stacking feature allow stack heights up to 100 mm (4") tall
- Slicer can be configured with one or two scales and classifiers for weighing sliced portions

Flexible Configuration to Meet Your Needs

- Choose Manual or Automatic product loading. See table at right for details of what is included with each model.
- Select from a variety of portion conveying options
- Optional single lane or dual lane interleaver available
- A 3-D product scanner can be added to the Automatic model to optimize slicing performance with irregularly shaped products
- Slicer can be reconfigured in the field should your business needs and slicing application change in the future



Automatic version of the SX330



Open, Hygienic Design

- Open, skeletal structure provides clear access to all components for easy cleaning and maintenance
- Control cabinet is mounted on the non-operator side of the machine, outside of the product drip zone
- Tool-free disassembly simplifies and speeds machine cleaning

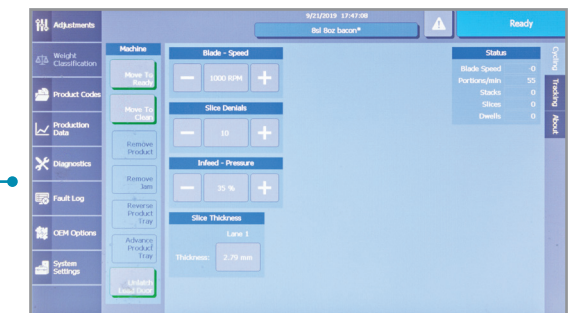

User-Friendly Touch Screen

- Large, 380 mm (15") touch screen stores and controls all pre-programmed operations
- Store product codes to ensure consistent and repeatable performance
- Intuitive screens simplify operation and troubleshooting

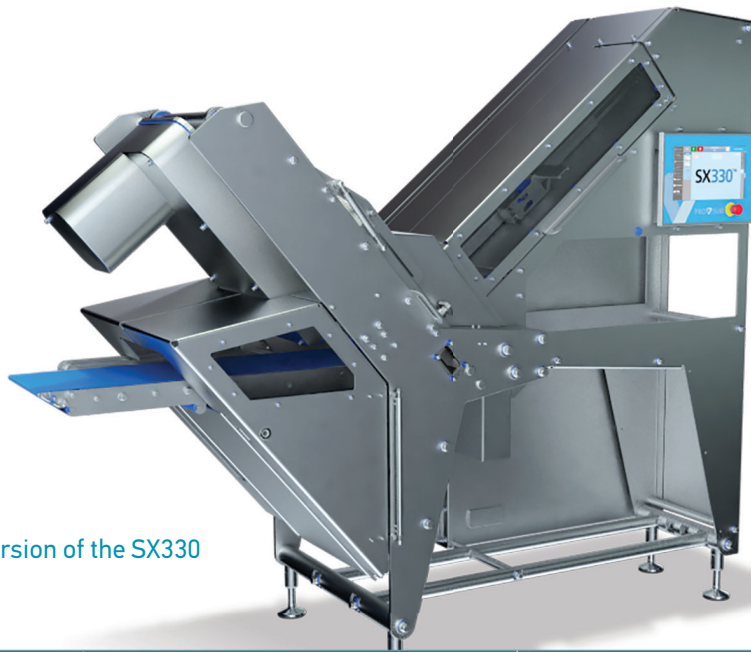

Manual version of the SX330

SPECIFICATIONS	SX330 — MANUAL	SX330 — AUTOMATIC
Throat Area	160 mm x 330 mm (6.3" x 13")	160 mm x 330 mm (6.3" x 13")
Number of Product Drives	1	1
Product Length	1000 mm (39.4")	1000 mm (39.4")
Blade Style	16.12" involute	16.12" involute
Blade Speed (RPM)	1000 involute	1500 involute
Blade Retract	None	Standard
Product Loading	Manual side	Automatic rear center
Lower Infeed	Slide plate	Driven conveyor
Upper Infeed	Non-driven upper paddles	Non-driven upper paddles
Bulk Conveyor	Standard 1220 mm (48") Optional 1830 mm (72") or 2440 mm (96")	Standard 1220 mm (48") Optional 1830 mm (72") or 2440 mm (96")
Stacking Conveyor	Optional, max stack height 100 mm (4")	Optional, max stack height 100 mm (4")
Scales and Classifiers	Optional 1 or 2 lanes	Optional 1 or 2 lanes
3-D Product Scanner	Not compatible	Optional
Interleaver	Optional, up to 2 lanes	Optional, up to 2 lanes

The **Formax® SX330** allows for fast runs and easy product changeovers to help smaller processors boost throughput and quality. An open, sanitary design allows for easy access to all components, so cleaning has never been easier. And while the SX330 takes up less floor space, its faster blade speeds and larger throat offer unmatched productivity for your growing business. The SX330 is available in two models — Automatic or Manual product loading. With many additional features available, you can configure the slicer to meet your production needs today and tomorrow.



Higher Slicing Capacity

- Available with blade speeds up to 1500 rpm, the SX330 offers higher throughput than comparable slicers in this size range
- Large slicing throat (160 mm x 330 mm/6.3" x 13") and longer product length (1000 mm/39.4") maximize overall capacity

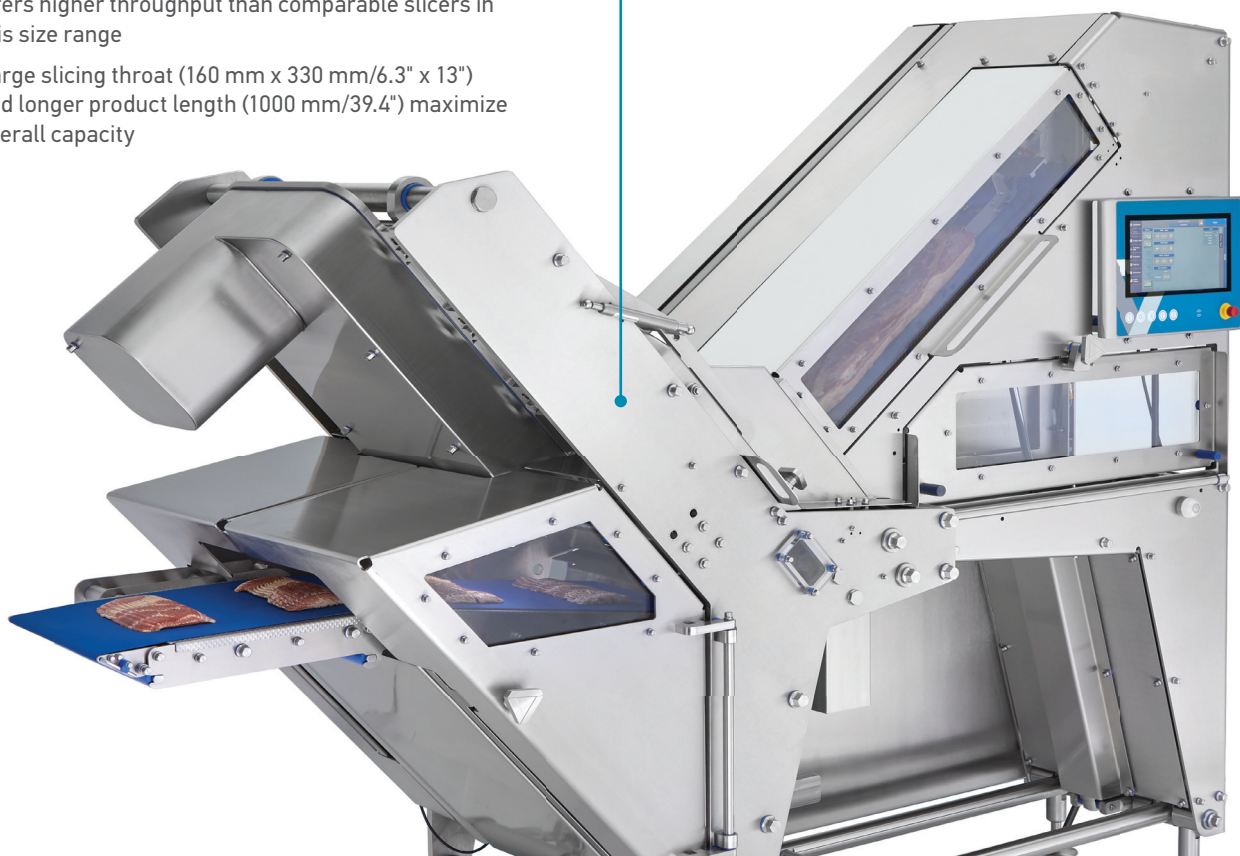

Choosing the Formax® SX330 assures you of service beyond compare

As your technology partner, we are committed to the shared responsibility of helping to maintain your slicing system at peak performance levels. It is also why we continuously invest in highly trained service professionals, each dedicated to providing you with 24/7/365 technical support, multi-lingual training, a complete OEM inventory and thorough equipment documentation. Rest assured, Provisur service and support will help reduce your total ownership cost and maximize the return on your SX330 investment.

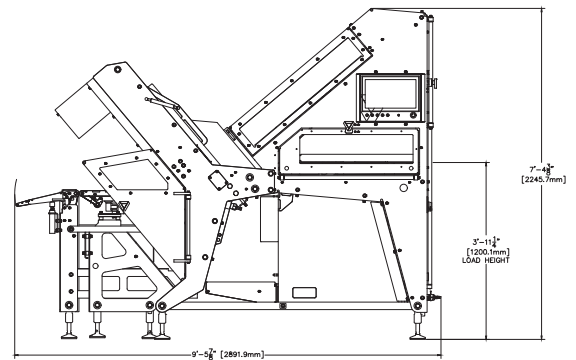
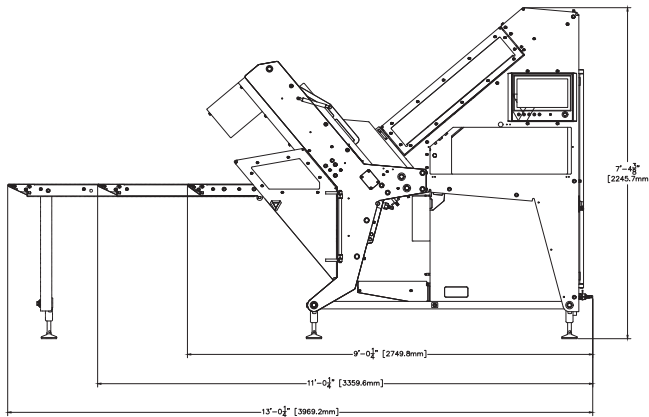
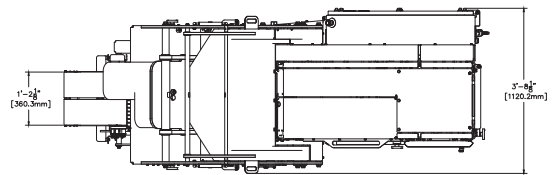
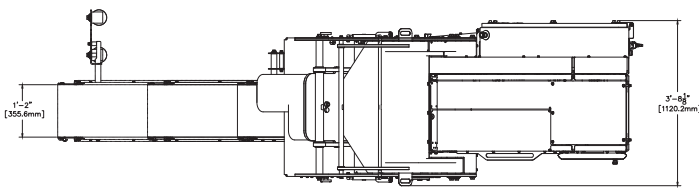

Scale and classifier option

Bulk conveyor options

Utilities

Electrical:
460/380 Volt, 30 Amp, 11 KVA

Pneumatic:
7 Bar, 70 L/min air supply
80 PSI, 2 CFM